

# UNCONTROLLED DOCUMENT

**CAUTION: STATIC SENSITIVE DEVICE**  
 FOLLOW PROPER E.S.D. HANDLING PROCEDURES  
 WHEN WORKING WITH THIS PART.

P/N PREFIX/SUFFIX TABLE		
LCM-X	GXX	DESCRIPTION
STANDARD	S	SR STN, REFLECTIVE
	SF	STN, TRANSFLECTIVE, (W/LED BACKLIGHT)
HIGH TEMP.	H	WF-C FSTN, TRANSFLECTIVE, (W/CCFL BACKLIGHT)
	H	WF-N FSTN, TRANSFLECTIVE, (W/EL BACKLIGHT)

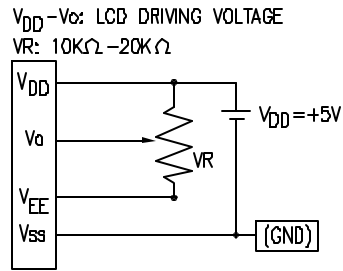

PART NUMBER		REV.
LCM-X24064GXX(-X)		A
REV.	E.C.N. NUMBER AND REVISION COMMENTS	DATE
A	E.C.N. #10571.	12-7-99

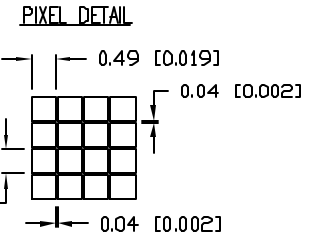
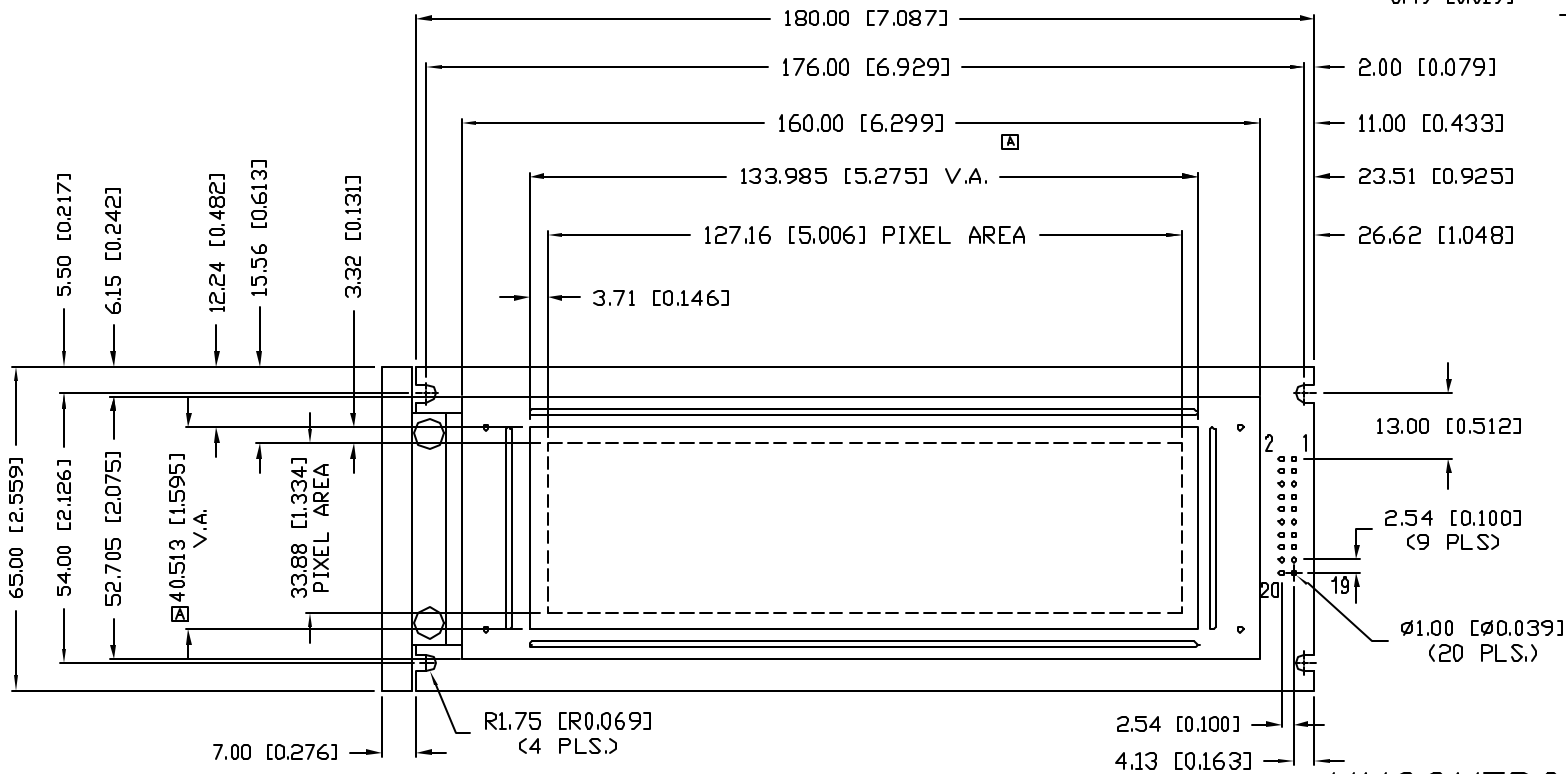

VERSION	A	B	MODULE SIZE
R & EL	5.2	11.5	180x65
CCFL	7.5	14.0	187x65
LED	9.1	14.0	180x65

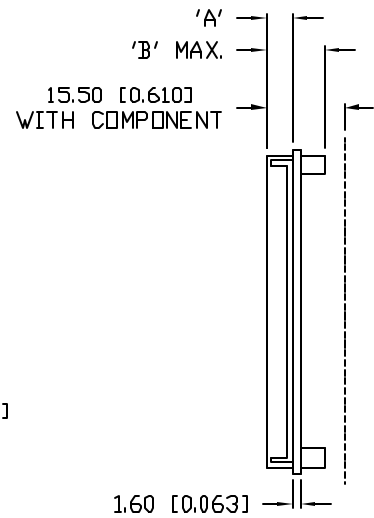

**UNCONTROLLED DOCUMENT**  
 \*UNLESS OTHERWISE SPECIFIED TOLERANCE IS  $\pm 0.25\text{mm}$  ( $\pm 0.010$ " )

REV.	PART NUMBER
A	LCM-X24064GXX(-X)
240 x 64 DOT MATRIX GRAPHIC MODULE, 1/64 DUTY, WITH NEGATIVE CHARGE PUMP.	

**CONFIDENTIAL INFORMATION**  
 THE INFORMATION CONTAINED IN THIS DOCUMENT IS THE PROPERTY OF LUMEX INC. EXCEPT AS SPECIFICALLY AUTHORIZED IN WRITING BY LUMEX INC, THE HOLDER OF THIS DOCUMENT SHALL KEEP ALL INFORMATION CONTAINED HEREIN CONFIDENTIAL AND SHALL PROTECT SAME IN WHOLE OR IN PART FROM DISCLOSURE AND DISSEMINATION TO ALL THIRD PARTIES.

**RELIABILITY NOTE**  
 OUR MANY YEARS OF EXPERIENCE DATA ACCUMULATION INDICATE THAT SOLDER HEAT IS A MAJOR CAUSE OF EARLY AND FUTURE FAILURE. PLEASE PAY ATTENTION TO YOUR SOLDERING PROCESS.

**LUMEX INCORPORATED**  
 290 E. HELLEN ROAD  
 PALATINE, ILLINOIS 60067  
 PHONE: 1-847-359-2790  
 WEB: HTTP://WWW.LUMEX.COM

DRAWN BY:	CHECKED BY:	APPROVED BY:	DATE: 2-18-99
SA/DU/BC			PAGE: 1 OF 2
			SCALE: N/A